

DELTA-AH

Exhaust Air Cowl

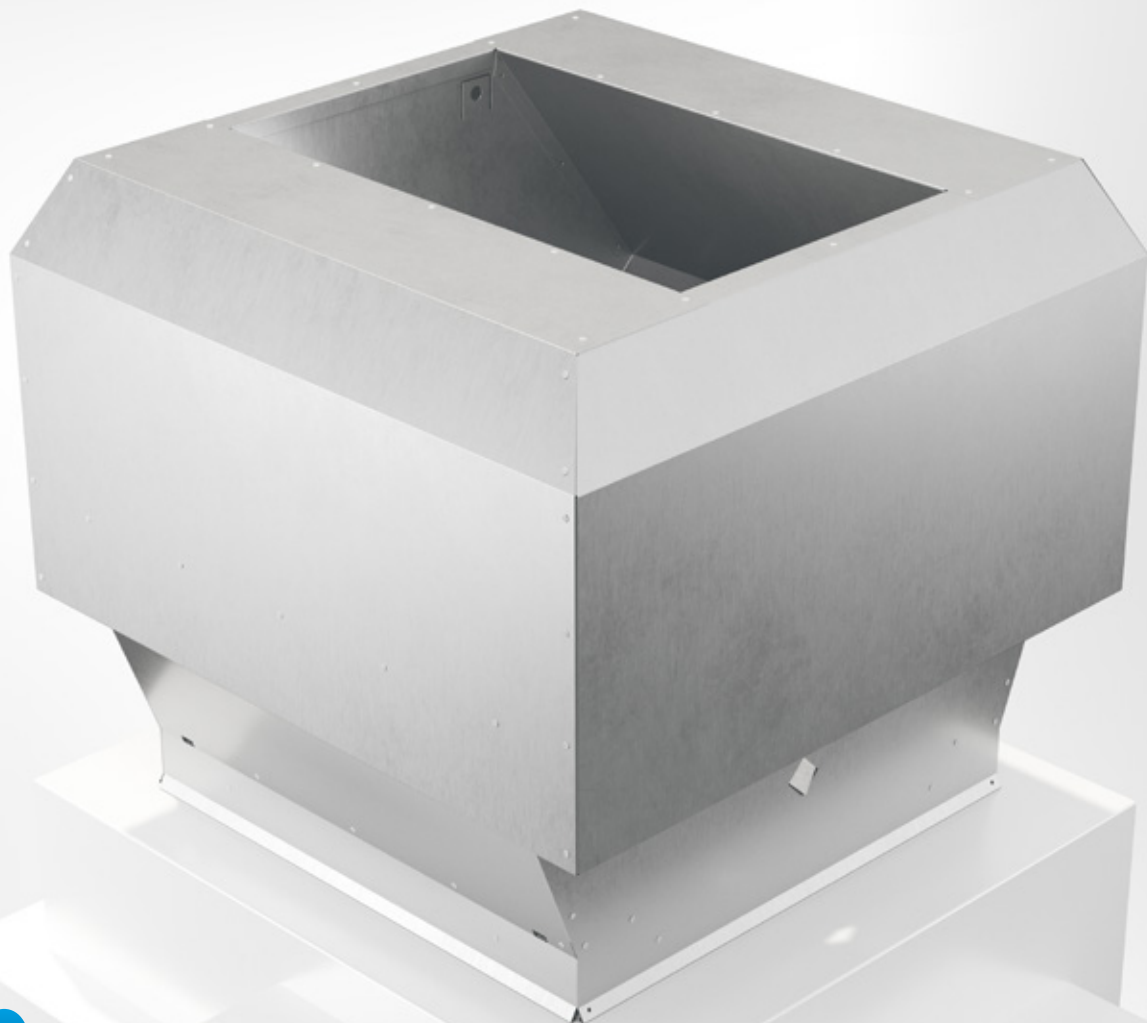

COWLS



03/03/2022



BEVENT RASCH

AIR SOLUTIONS – FOR A BETTER TOMORROW

www.bevent-rasch.com



Design is also available as Intake Air Cowl DELTA-UH and as Combination Cowl DELTA-KH.

Quick facts

- Sizes for flows from 100 l/s to 15.000 l/s
- Design similar to Intake Air Cowl DELTA-UH and Combination Cowl DELTA-KH
- Water separation Class A according to EN 13030
- Low pressure drop
- Adjustable outlet as accessory
- Integrated lifting points
- Available in MagiCAD

Use

DELTA-AH is a exhaust air cowl for use in comfort and industrial facilities. DELTA-AH is designed for a low pressure drop in combination with very good water separation. DELTA-AH has a design feature allowing the extracted air to rise straight up at increased speed. Supplied as standard with integrated lifting points to facilitate installation. DELTA-AH can be equipped with roof inlet BRTG for passage and access through outer roofing. Eyebolts can be supplied if necessary (state in plain text when ordering).

Adjustable outlet

Adjustable outlet as accessory. This to optimize the outlet velocity.

Material, finish

The air cowl is manufactured as standard in galvanized sheet-steel, corrosivity class C3 and can be supplied finished corrosivity class C4 in the desired colour, see www.bevent-rasch.com. The air cowl can also be supplied in the new material Magnelis in corrosivity class C5, Aluzinc AZ185 or stainless steel AISI 316L (EN 1.4404).

Specification

Examples:

Exhaust Air Cowl **DELTA-AH - 300 - 1 - 0**

Size, see size table

Material:

Galvanized sheet steel	= 1
Stainless AISI 316L – EN 1.4404	= 3
Aluzinc AZ185	= 4
Magnelis C5	= 5

Surface treatment:

Unfinished C3	= 0
Painted finish C4	= 1*

* Colour code should be stated in plain text, see www.bevent-rasch.com

Accessories:

Adjustable outlet, DELTA-SU

Roof inlet BRTG, see www.bevent-rasch.com

Special

The air cowl can be supplied in many different custom designs concerning dimensions, choice of material, etc. CFD-simulation can also be performed for custom designs. Please contact Bevent Rasch by email info@bevent-rasch.se.



Selection chart

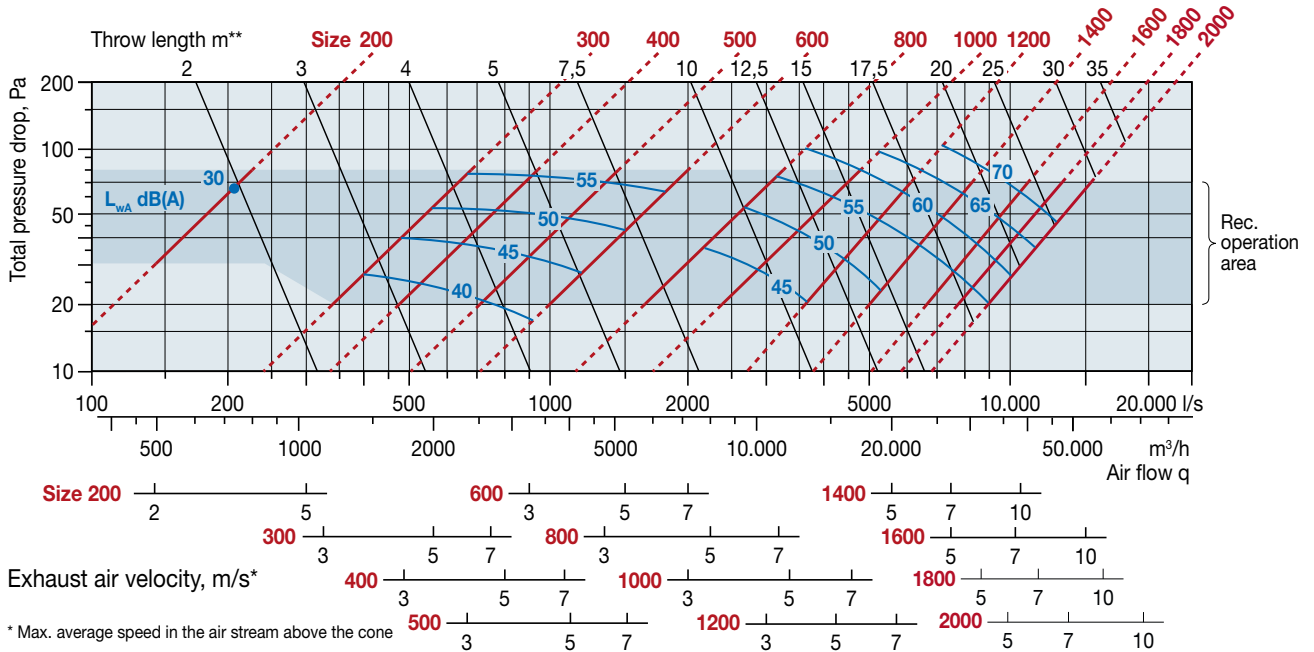

* Max. average speed in the air stream above the cone
 ** Throw lengths are simulated and applied in windless conditions. The dimensions are defined in meters as the distance from the outlet of the hood to the point where the velocity of the air plume has decreased to 2 m/s

Correction of the sound power level, L_{wok} in octave band

$$L_{wok} \text{ (dB)} = L_{wA} + K_{ok}$$

Octave-band	63	125	250	500	1000	2000	4000	8000
K_{ok}	4,4	3,1	0,5	-2,3	-5,6	-12,1	-14,4	-20,1

Reduction in sound pressure level depending on distance from roof cowl calculated on fully spherical propagation.

Distance, m	5	25	50	75	100	150
Reduction, dB(A)	-22	-36	-42	-45	-48	-52

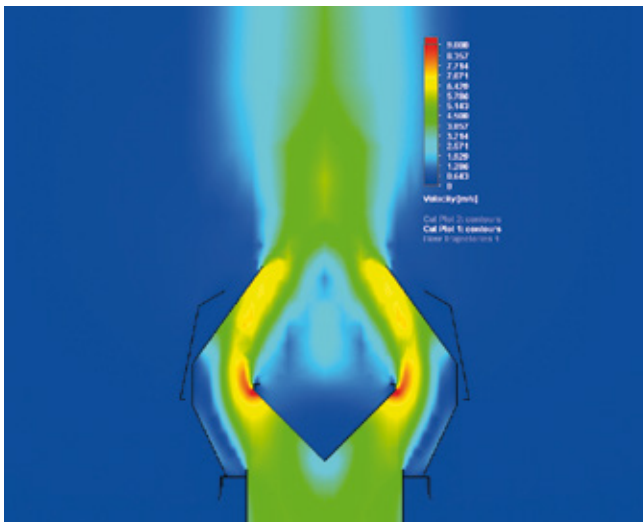

We have used the latest CFD technology when we developed the DELTA-series.



Dimensions

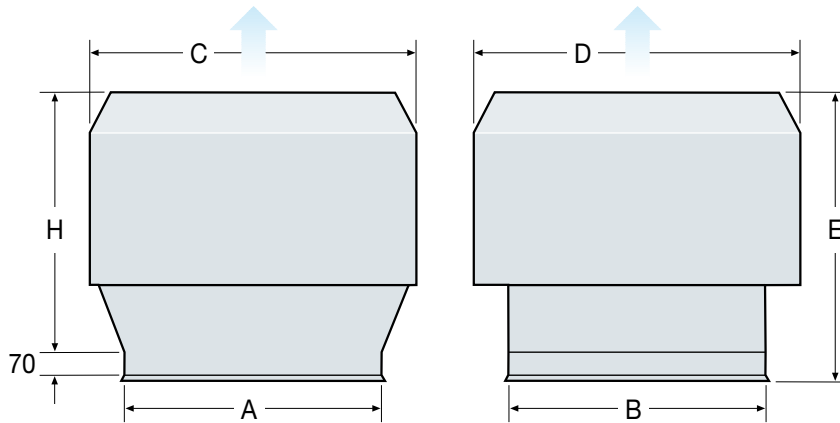

Size	A	B	C	D	E	H	BRTG	Weight kg
200	400	400	510	510	505	405	3	14
300	500	500	635	635	605	505	4	22
400	600	600	760	760	710	610	5	30
500	700	700	890	890	810	710	6	40
600	800	800	1015	1015	910	810	7	52
800	1000	1000	1270	1270	1110	1010	9	80
1000	1200	1200	1530	1530	1315	1215	11	113
1200	1400	1400	1780	1780	1520	1420	13	162
1400	1600	1600	2035	2035	1720	1620	15	209
1600	1800	1800	2290	2290	1920	1820	17	262
1800	2000	2000	2545	2545	2125	2025	19	321
2000	2200	2200	2800	2800	2325	2225	21	386